

# 55 Gallon Drum Work Station

## Owners Manual

---

### **IMPORTANT**

- Please read this Owners Manual carefully and thoroughly before installing and operating your 55 Gallon Drum Work Station.
- Please retain this owners manual for future reference after reading it thoroughly.





## TABLE OF CONTENTS

Explanation of Symbols used .....	2
Warnings and Cautions .....	3
OilSafe Limited Warranty .....	4
Introduction .....	5
Parts and Pre-Installation Checklist .....	6
Electrical Installation .....	7
Setup and Initial Operation .....	8
<i>Tools, Materials, and Personnel Requirements</i>	
<i>Determine Placement</i>	
Installation .....	9
<i>Initial Operation</i>	
Maintenance .....	12
<i>Requirements Prior to Maintenance</i>	
<i>Maintenance Checklist</i>	
Troubleshooting .....	13
Repair and Replacement Procedures .....	15
Replacement Parts .....	16
Tank or Motor Replacement .....	18
Customer Service and Warranty Issues .....	19

## FOR YOUR RECORDS

### Write the model and serial numbers here:

*(You can find them on the Serial/Model No. Plate mounted at the rear of your system on a lower tank frame rail.)*

Serial / Model #: \_\_\_\_\_

Supplier Name: \_\_\_\_\_

Date Purchased: \_\_\_\_\_

## READ THIS MANUAL

Inside you will find important information on how to use and maintain your 55 Gallon Drum Work Station.

## INTELLECTUAL PROPERTY

OilSafe® is a Registered Trademark of Whitmore.

All Trademarks are the property of their respective owners.

All Rights Reserved.

Patents Pending.

©2016 Whitmore

## EXPLANATION OF SYMBOLS USED

This manual contains some common symbols and indications to alert you to specific areas of importance.



---

### **WARNING!**

A situation that, if not avoided, could result in severe property damage, equipment damage, severe injury, or even death. FAILURE TO FOLLOW this warning will void your product warranty.



---

### **CAUTION!**

A situation that, if not avoided, could result in property damage, equipment damage, or injury. FAILURE TO FOLLOW this caution will void your product warranty.

### **IMPORTANT:**

This text will be used before text that has been designated as important to the proper installation, operation, or maintenance of your system. FAILURE TO READ and understand this text may result in improper installation, operation, or maintenance procedures and may void your warranty.

### **TIP:**

This text will be used to highlight text that is helpful in the installation, operation, and maintenance of your system.

### **NOTE:**

This text will be used to highlight text that is important to read in order to fully understand the terms and procedures used in this manual.

## WARNINGS AND CAUTIONS

The OILSAFE® 55 Gallon Drum Work Station is designed for the storage of machinery lubricating oils and other NON-VOLATILE fluids. STORAGE OF FLUIDS WITH A FLASHPOINT BELOW 150°F (65.5°C) IS STRICTLY PROHIBITED.

Components within this system consist of materials that may not be compatible with your fluid. ALWAYS consult your supplier and refer to the fluid manufacturer's Material Safety Data Sheet ("MSDS") before introducing a fluid to this system.



### WARNING!

ALWAYS ensure the main power supply is first locked out and the system depressurized before any service is performed on this system. NEVER connect or disconnect lines or change filter elements or undertake any service work when this system is running or energized. SEVERE INJURY OR DEATH MAY OCCUR.



### CAUTION!

System Operating Pressure should NEVER exceed 300 PSI. Operating pressures can be regulated by adjusting pump bypass relief valves located on pump heads to suit specific lubricant viscosities and temperatures.

### IMPORTANT:

ALWAYS REFER TO THIS MANUAL OR CONSULT YOUR SUPPLIER FOR MORE INFORMATION.

- ALWAYS ensure that you wear appropriate Personal Protective Equipment ("PPE") when operating this system.
- ALWAYS ensure that all system hoses, filters and fittings are securely fastened and in good working condition.
- THE OIL DRUM MUST ALWAYS BE VENTED TO ATMOSPHERE (preferably utilizing a Desiccant Air Breather).
- When dispensing or recirculating ALWAYS ensure the grounding cable is connected to the drum or barrel before starting the pump.
- ALWAYS ensure the system is appropriately grounded to earth utilizing relevant grounding equipment as specified and installed by your authorized electrical personnel in accordance with your local and federal regulations and safety procedures.
- Ambient room temperature where the system is installed should be in the range of 60°F (15°C) TO 80°F (26°C) with optimum room temperature being 70°F (21°C). For ambient temperatures below 60°F (15°C) consult the manufacturer or your supplier for the supply of electric blanket heaters for oil barrels, pails and bulk tanks to ensure stability of lubricant viscosity, condition and system performance. Temperatures less than (<60°F / 15°C) can result in lubricant viscosity increasing above the rated ISO Code you specified at the time of order. Such adverse viscosity changes can cause higher system operating pressures than those set at the factory. System operating pressure should never exceed 300 PSI as this can cause a gasket failure on the spin-on filter resulting in a high pressure oil leak. Normal system operating pressure should be less than 240 PSI. Operating pressures above 240 PSI will necessitate adjustment of the pump pressure relief bypass valve located on the pump head. Contact the manufacturer for more information prior to commissioning the system if the ambient room temperature will ever fall below 60°F (15°C).



### WARNING!

FAILURE TO FOLLOW System installation, safety and operating instructions may result in SEVERE INJURY OR DEATH, damage to plant and equipment and void warranties.

## OILSAFE LIMITED WARRANTY

OilSafe (“OS”) warrants to the original product purchaser (hereinafter the “Customer”) that the OS product for which the Customer received this warranty was designed, developed and manufactured using all due reasonable commercial care and good manufacturing practices. OS’ products shall be free from defects in material and workmanship for 365 days from the original date of purchase by Customer. OS’ sole obligation under this warranty is to repair or replace the product, at OS’ option. OS must be notified by Customer in writing of any claim under this warranty within 30-days of any claimed lack of conformity of the product. THIS WARRANTY IS INTENDED TO BE IN LIEU OF ALL OTHER WARRANTIES, WHETHER EXPRESS OR IMPLIED. OS SPECIFICALLY DISCLAIMS THE IMPLIED WARRANTIES OF MERCHANTABILITY AND FITNESS FOR A PARTICULAR PURPOSE.

### Warranty Limitations:

In no event shall OS be liable for any loss, inconvenience or damage, whether direct, incidental, consequential or otherwise, resulting from breach of any express or implied warranty or condition, of merchantability, fitness for a particular purpose or otherwise with respect to this product, except as set forth herein. Some states or countries do not allow limitation on how long an implied warranty lasts so the above limitations or exclusions may not apply to you. This warranty gives you specific legal rights, and you may also have other rights, which may vary, from location to location. This warranty will be interpreted pursuant to the laws of the United States and the State of Illinois. The original English language version (meaning) of this warranty controls over all translations; OS is not responsible for any errors in translation of this warranty and/or any product instructions. This warranty is not intended to confer any additional legal, jurisdictional or warranty rights to you other than those set forth herein or required by law. If any portion of this warranty is held to be invalid or unenforceable for any reason, such finding will not invalidate any other provision. For products purchased in countries other than the United States, please contact OS’ authorized representative (i.e., the ‘company’ or ‘person’ who represented OS or brokered the ‘sale’) in the country where the product was purchased.

### Warranty Service Options:

For service under this warranty you must notify OS in writing. Such notification must specify in writing the product in question by model and serial number, applicable purchase order number and/or the original of date of your written notification.

*You may contact OS as follows:*



**930 Whitmore Drive  
Rockwall, TX 75087 USA**

**Telephone: (972) 771-1000**

**Fax: (972) 722-3252**

**Email: [sales@oilsafe.com](mailto:sales@oilsafe.com)**

**[www.oilsafe.com](http://www.oilsafe.com)**

Any insurance and/or shipping costs incurred in returning your OS product for service pursuant hereto are your responsibility. OS will not be responsible for any products lost or damaged in shipment.

### Warranty Exclusions:

Representatives and brokers of OS products are not authorized to modify this warranty in any way. It is the Customer’s responsibility to regularly examine the product to determine the need for normal service or replacement. This warranty does not cover the following:

- Products that have been modified, neglected or poorly maintained, misused, abused or involved in accidents or natural disasters.
- Damage occurring during shipment of the product (such claims must be presented directly to the freight forwarder or shipping company).
- Damage to the product resulting from improper maintenance or repair, the use or installation of parts and/or accessories that are not compatible with the original intended use of the product, or the failure to follow the product warnings and usage instructions.
- Damage or deterioration to the surface finish, aesthetics or appearance of the product.
- The labor costs required to remove and/or refit and readjust the product covered by this warranty.
- Normal wear and tear to the product.
- Filter Cartridges, Desiccant Air Breathers, Level Gauges and other consumable items.
- Service Trips to Customer’s location to teach Customer how to use the product.
- Defects that result from improper installation or damage not cause by OS.
- Damage to the product caused by accident, fire, floods or other acts of God.
- Or, any products for which the Customer does not follow the warranty procedures outlined above.

## INTRODUCTION

Thank you for purchasing an **OilSafe® 55 Gallon Drum Work Station**. This system was designed to dispense bulk lubricants in the workplace. The system was designed with quality in mind and is fully modular. The installation, operation, and maintenance instructions in this document will provide you with all the information you will need for the lifetime of your system.

Your system was designed to store and dispense lubricants up to ISO 680 (if specified at the time of order).

**FIGURE 1:** Schematic of 55 Gallon Drum Work Station

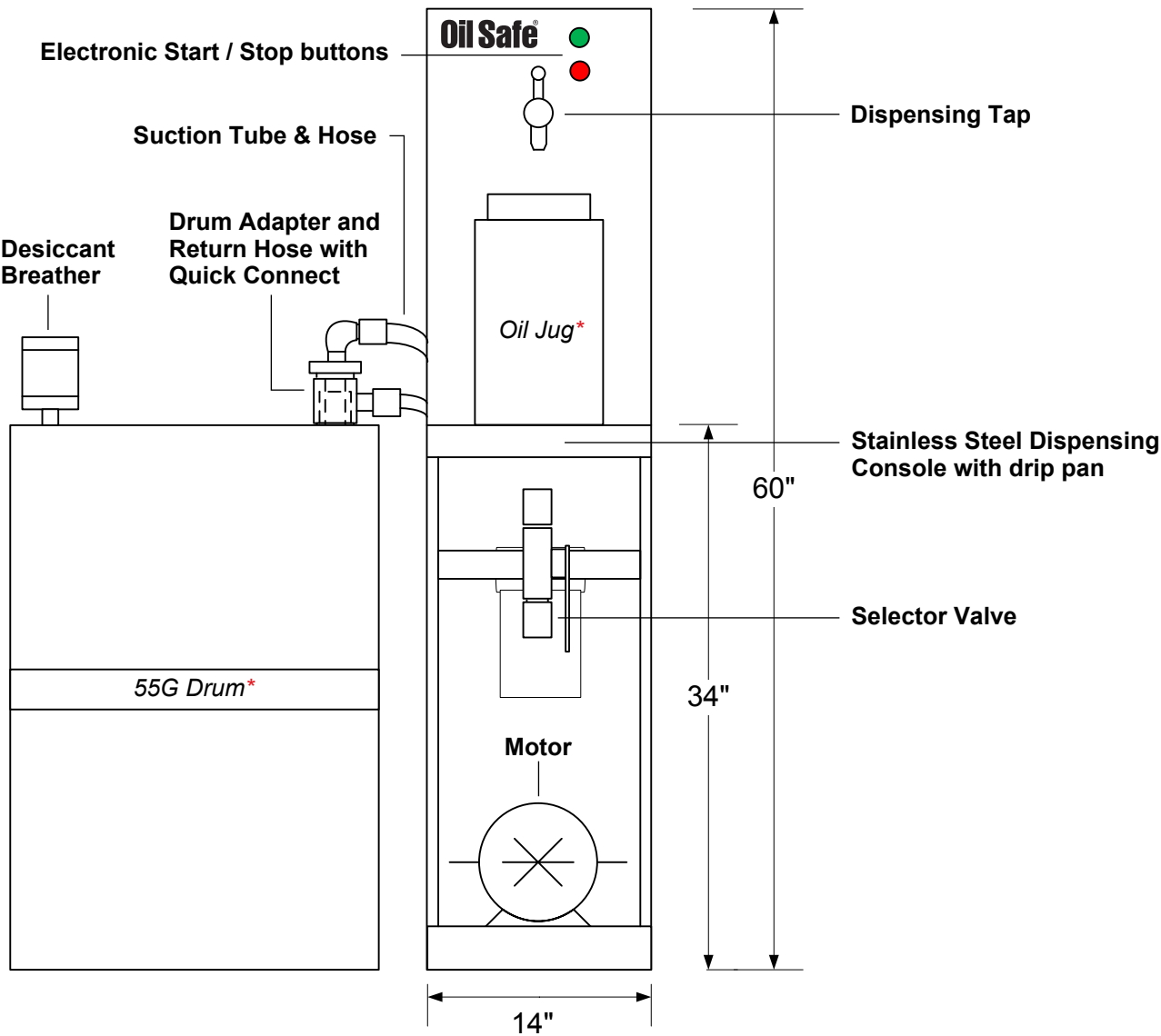

\* NOTE: 55 Gallon Drum and Oil Jug not included.

## PARTS AND PRE-INSTALLATION CHECK LIST



### IMPORTANT:

CHECK packaging list to ensure you have all applicable parts before continuing. CONTACT YOUR SUPPLIER if it appears that any parts are missing or damaged. Refer to the specification sheet for your customized system for detailed system information including electrical requirements, and total weight of system.

OS has completed the assembly for the Work Station. The only installation and assembly required after delivery is connecting the Work Station to the 55 gallon drum, connecting the power and making sure of the ground.

***Please make sure operating valves are in “Recirculation” positions before start-up and at shut-down of units. This provides the lowest amp draw and system pressure, ensuring the safest conditions for operators during start-up and shut down of the unit.***

### Barrel Pump System:

- 4 Motor/Pump (pre-installed)
- 4 Dispensing Faucet is the spring back type
- 4 Cartridge type filter
- 4 Desiccant Air Breather Air Filter
- 4 Suction Hose Assembly
- 4 Selector Valve (located beneath dispensing station)
- 4 Static Discharge Grounding Wire



**FIGURE 2:** Static Discharge Grounding Wire



## ELECTRICAL INSTALLATION

### IMPORTANT:

Plug the power cords into a wall outlet or proper extension cord. MAKE SURE there is a good electrical ground and that the voltage supplied is appropriate to the motor specified.



---

### WARNING!

FAILURE TO FOLLOW system installation, safety and operating instructions may result in severe injury or death, damage to plant and equipment and void manufacturer warranties.

The following instructions should be carried out by a trained and authorized electrician or electrical personnel in accordance with your local and federal regulations and safety procedures.

ALWAYS ensure the system is appropriately grounded to earth utilizing the grounding lugs provided at the rear base of the system, together with relevant grounding equipment as specified and installed by your authorized electrical personnel.



**FIGURE 3:** Overview of Barrel Pump Connected to Drum

## SET UP & INITIAL OPERATION

### Tools, Materials, and Personnel Requirements:

- Electrical hook-ups and installation should be completed by your authorized electrical personnel in accordance with all local and federal laws and regulations.
- Personal Protective Equipment (“PPE”) should be worn when installing and operating this system.

### Determine Placement:

1. The system should be installed indoors on a flat, level surface with sufficient load-bearing capacity to support the total system weight.
2. The Work Station REQUIRES a separate power outlet. See your specification sheet (or system supply quotation) for electrical requirement details. Consult with an authorized and trained electrician.
3. BEFORE beginning installation, determine where your system will be installed and ensure sufficient power outlets have been installed at the rear of the system, positioned behind where the motors will be located. Each power outlet should be equally spaced along the wall and be placed approximately 12" up from floor level.

### IMPORTANT:

- It is important to note the effect of the ambient temperature in which the system is placed for operation. System room temperature should be in the range of 60°F (15°C) TO 80°F (26°C) with optimum room temperature being 70°F (21°C). For ambient temperatures below 60°F (15°C) consult the manufacturer or your supplier for the supply of electric blanket heaters for oil barrels, pails and bulk tanks to ensure stability of lubricant viscosity, condition and system performance.
- Temperatures less than (<60°F / 15°C) can result in lubricant viscosity increasing above the rated ISO Code you specified at the time of order. Such adverse viscosity changes can cause higher system operating pressures than those set at the factory.
- System operating pressure should never exceed 300 PSI as this can cause a gasket failure on the spin-on filter resulting in a high pressure oil leak. Normal system operating pressure should be less than 240 PSI. Operating pressures above 240 PSI will necessitate adjustment of the pump pressure relief bypass valve located on the pump head.
- Contact the manufacturer for more information prior to commissioning the system if the ambient room temperature will ever fall below 60°F (15°C).

## INSTALLATION



### CAUTION!

Personal Protective Equipment (“PPE”) should be worn when installing and operating this system.

System Operating Pressure should NEVER exceed 300 PSI. System operating pressures can be regulated by adjusting pump bypass relief valves located on pump heads to suit specific lubricant viscosities and temperatures.

System SHOULD NOT be operated in a location with an ambient room temperature less than 60°F/15°C. Contact the manufacturer for more information relating to service in cold environments.

1. Place the system next to the 55 gallon drum to be dispensed from.
2. Mount suction hose adapter to the drum. Install the desiccant breather. Connect the smaller recirculation hose to the fitting on the barrel adapter.
3. Connect suction hose to the quick coupler on the barrel pump. Slide the suction wand through the barrel adapter and into the drum.
4. Make sure barrel pump is connected to ground and clip grounding wire at rear of barrel pump to the oil drum being dispensed from.
5. Connect the barrel pump to an appropriate electrical supply.
6. Place the selector valve in either the “Dispense ” or “Recirculate” position.
7. Push the green button to activate the pump. Oil should be pumped from the barrel through the clear suction hose and will recirculate or may be dispensed depending on the position of the selector valve.
8. Place a suitable container under the tap. Oil will be dispensed when the handle is deflected. Selector valve should be in the “Dispense” position.
9. Lubricant can be kidney looped through the filter if desired by placing the selector valve in the “Recirculate” position and activating the pump.
10. The pump should not be left running for an extended period unless the selector valve is in the “Recirculate” position.



**FIGURE 4:** Selector Valve in Recirculate Position. Move handle down for Dispense Position.

## Initial Operation

The first time the system is used there will be some air that has been trapped in the hoses. This is NORMAL and will not affect the system. Simply wait for the air to stop coming out of the lines and fluids to dispense normally before continuing. If air continues to come out of the hoses after the initial use, there may be a problem with a seal or a hose. See the Troubleshooting Section of this manual, or contact your supplier for additional support.



### CAUTION!

ALWAYS monitor the system whenever the pump is running or fluid is dispensing.

System Operating Pressure should NEVER exceed 300 PSI. Operating pressures can be optimized by adjusting pump bypass relief valves located on pump heads to suit specific lubricant viscosities and temperatures.

Normal operating pressure when filling, dispensing or re-circulating is typically less than 30 PSI. Normal operating pressure when running the pump against a closed dispensing faucet (bypassing) is typically in the range of 70 PSI – 200 PSI. Should the relief valves require adjustment to optimize performance the instructions can be found in the Troubleshooting Section beginning on page 13.

## ***INITIAL OPERATION CONTINUED***

1. Place the tube-end of the Suction Hose Assembly into the oil drum or container (55-gallon drum). ***SEE FIGURE 5 BELOW.***



### **CAUTION!**

When pumping from a barrel MAKE SURE ground wire is attached.

## ***INITIAL OPERATION CONTINUED***

2. Attach the Static Discharge Cable to the drum. ***SEE FIGURE 6 BELOW.***

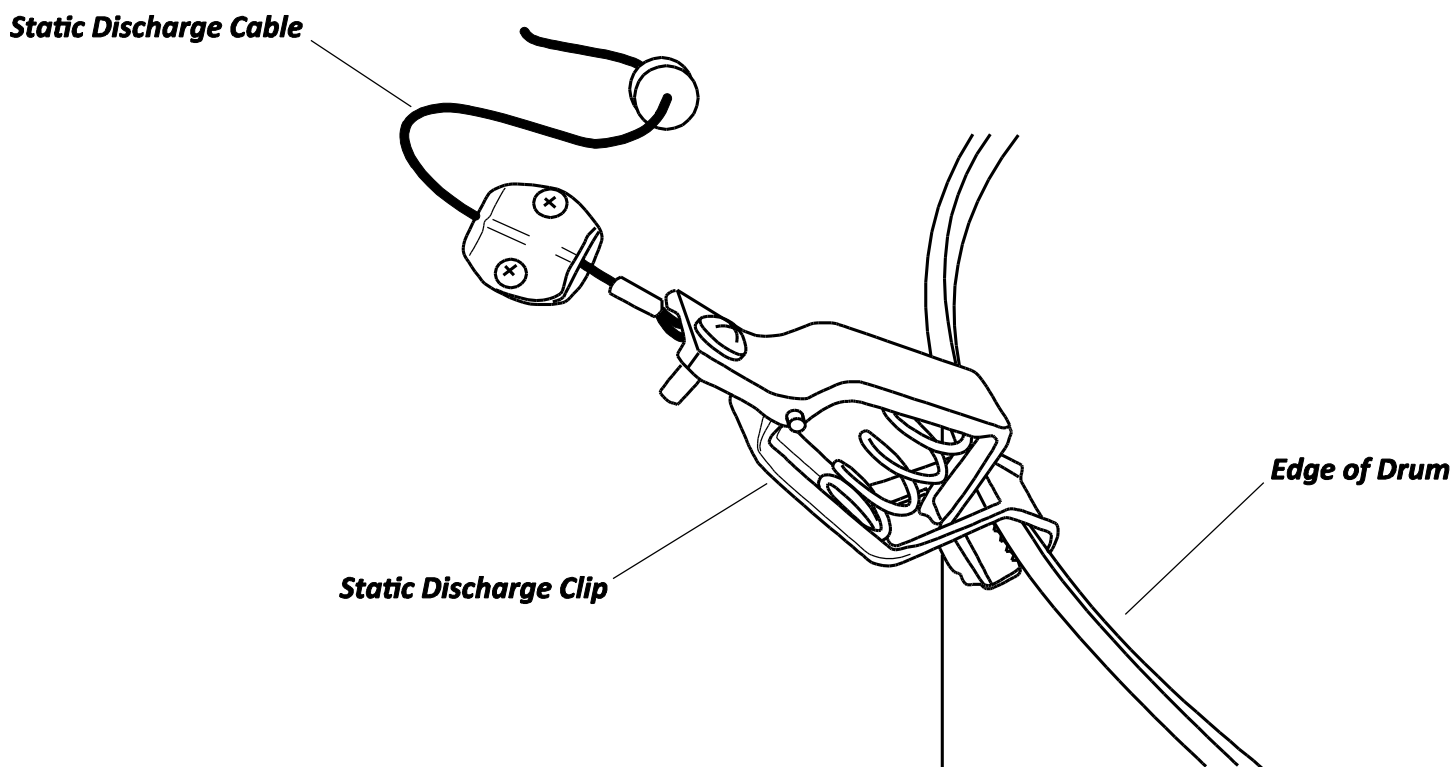

### **CAUTION!**

When dispensing from drums or barrels ALWAYS ensure the Static Discharge Clip is connected to the drum or barrel before starting the pump.

## MAINTENANCE

Periodic maintenance should be scheduled and performed on your system every three months after your initial installation.

### Requirements Prior to Maintenance:



#### WARNING!

ALWAYS ensure the main power supply is first locked out and the system depressurized before any service is performed on this system. NEVER connect or disconnect lines, change filter elements, or undertake any service work when this system is running or energized. SEVERE injury or death may occur.



#### CAUTION!

Personal Protective Equipment (“PPE”) should be worn when installing and operating this system.

### Maintenance Checklist:

#### EVERY 3 MONTHS:

- 4 Check Filter. Filter housing may have an alarm to indicate a clogged filter.
- 4 Check Desiccant Air Breathers.

#### EVERY 6 MONTHS:

- 4 Replace Filter as required.
- 4 Replace Desiccant Air Breathers as required (orange beads will turn dark green indicating the filter is used).
- 4 Inspections:
  - Inspect all hoses for cracks or kinks.
  - Inspect all hose fittings for cracks or leaks.
  - Inspect and tighten all bolts.
- 4 Clean external surfaces: (Use an environmentally friendly cleaning/degreasing fluid and warm water. Rinse completely before replacing.)
  - Remove drip-pans from beneath the faucets, clean the entire grate and flush the pan.
  - Remove faucet nozzles by unscrewing, clean heads and o-rings. Flush out the spill transport pallet (bottom of the pods) with hot water and cleaner/degreasing fluid.
- 4 Use a clean and damp rag and wipe down the motor and all painted surface areas.
- 4 Polish all stainless steel areas with stainless steel cleaner.
- 4 Dust the motor fan.



#### WARNING!

OilSafe DOES NOT recommend changing the type of fluid dispensed by a pump. Each system is custom-built to customer specifications including the type of fluid stored. Contact your supplier if your fluid storage needs change to remove the possibility of cross-contamination and incompatibility of system materials or components with a new fluid.

Also be aware of any change in ambient room temperature in the new location. Ambient room temperature should not be less than 60°F (15°C).

## TROUBLESHOOTING



### WARNING!

ALWAYS ensure the main power supply is first locked out and the system depressurized before any service is performed on this system. NEVER connect or disconnect lines, change filter elements, or undertake any service work when this system is running or energized. SEVERE injury or death may occur.

The Tank Isolation Valves (located on the underside of each tank) must be in the open position when operating the system and in the closed position when servicing the system.

The following troubleshooting procedures will help you identify and correct problems with your system. Every part of the system has been designed per your specifications and should not require maintenance, repair, or calibration beyond what was described in the maintenance section of this document.

If any of these troubleshooting procedures do not solve the issue, contact your supplier for additional support.

Issue	Steps to Resolve
<b>The Work Station is not dispensing correctly.</b>	<ol style="list-style-type: none"> <li>1. Check that selector valve is in proper position.</li> <li>2. Check fittings for cracks and leaks.</li> <li>3. Check the motor for correct rotation. If not, contact electrician.</li> <li>4. Make sure the suction hose and wand are connected to the Work Station, that the wand is inserted in the barrel, that the pump is running in the correct direction, and that the drum is vented (preferably with a desiccant filter installed in the vent hole).</li> <li>5. Check the seals on the suction hose assembly. Replace if cracked or damaged.</li> <li>6. Ensure the Desiccant Air Breather is not plugged.</li> <li>7. Check and clean the dispensing faucet to remove dirt, debris or clogs.</li> </ol>
<b>The motor stops working.</b>	<ol style="list-style-type: none"> <li>1. Check electrical enclosure to ensure power is applied to the pump.</li> <li>2. Check all circuit breakers to ensure power is available. Check the power cord from the electrical enclosure to the motor for cracks or problems.</li> <li>3. Check the power cord connector at the motor to ensure all the pins are seated correctly and that the connector is clean of dirt and debris.</li> </ol>



## ***TROUBLESHOOTING CONTINUED***

<b>Issue</b>	<b>Steps to Resolve</b>
<p><b>The pump system pressure is above 240 PSI.</b></p>	<ol style="list-style-type: none"> <li>1. Locate the pump bypass pressure relief valve on the side of the pump head.</li> <li>2. Using a wrench, loosen the lock nut on the valve spindle by turning it counter clock wise.</li> <li>3. Turn the valve spindle counter clock wise until it comes to a stop. This will result in the pressure relief valve now being in the lowest possible pressure setting.</li> <li>4. Position the selector valve (at the front of the system) for the pump in question into the dispense position</li> <li>5. Have an additional operator stand at the control panel and start the pump and have them monitor the pump pressure gauge. Normal system pressure when running the pump in dispense mode (with the dispensing faucet in the closed position) should be in the range of 110 PSI – 240 PSI.</li> <li>6. To increase the pressure back up to be within the normal 110 PSI – 240 PSI range, carefully adjust the bypass pressure relief valve spindle (with the pump running) by slowly turning the valve spindle clock wise while the operator monitors the pressure gauge. This pressure setting readjustment will likely take 1.5 to 2.5 turns of the valve spindle depending on oil viscosity and operating temperature.</li> <li>7. Once desired pressure has been achieved, re-tighten the valve spindle lock nut by turning the nut clock wise.</li> </ol>
<p><b>The pump system pressure is above 240 PSI AND the system is operating in a cold environment (less than 60°F / 15°C).</b></p>	<ol style="list-style-type: none"> <li>1. Ambient room temperature where the system is installed should be in the range of 60°F (15°C) TO 80°F (26°C) with optimum room temperature being 70°F (21°C). For ambient temperatures below 60°F (15°C) consult the manufacturer or your supplier for the supply of electric blanket heaters for oil barrels, pails and bulk tanks to ensure stability of lubricant viscosity, condition and system performance.</li> <li>2. Temperatures less than (&lt;60°F / 15°C) may result in lubricant viscosity increasing above the rated ISO Code you specified at the time of order. Such adverse viscosity changes can cause higher system operating pressures than those set at the factory. System operating pressure should never exceed 300 PSI as this can cause a gasket failure on the spin-on filter resulting in a high pressure oil leak.</li> </ol>



## REPAIR AND REPLACEMENT PROCEDURES



### **WARNING!**

ALWAYS ensure the main power supply is first locked out and the system depressurized before any service is performed on this system. NEVER connect or disconnect lines, change filter elements, or undertake any service work when this system is running or energized. SEVERE injury or death may occur.

The major components of the system were designed to be line replaceable. Before attempting any repairs or replacement, contact OilSafe in the event your part is covered by warranty.

*You may contact OS as follows:*



930 Whitmore Drive  
Rockwall, TX 75087 USA

Telephone: (972) 771-1000  
Fax: (972) 722-3252  
Email: sales@oilsafe.com  
www.oilsafe.com

**Do not disassemble any part of the system without authorization from OS. Failure to receive this authorization will void your product warranty.**

**The following parts of your system are replaceable. Contact your supplier for ordering information.**

- The Motor and Pump can be replaced.  
*Contact your supplier for specific instructions and have your system specification sheet at hand.*

# REPLACEMENT PARTS

## Tank Desiccant Air Breather (Part # 46Z134)

This is the air filter on the top of the tanks. When the colored beads on the inside of the breather turn from orange to dark green, it is time to replace the filter. The filter can be screwed on and off.

## Colored Ball Knob for Standard Steel Shut Off Valve (Available in 10 colors – See Table 1 on page 17 for Part #'s)

The ball knob on the end of the Dispensing Faucet Handle is color-coded to match the fluid tank it corresponds with. If the ball knob is damaged or requires replacing for any reason, it can be removed by unscrewing it from the handle and replacing it with a new knob. Be sure to keep the color-coded system in place to allow users to easily recognize which Dispensing Faucet goes with each tank.

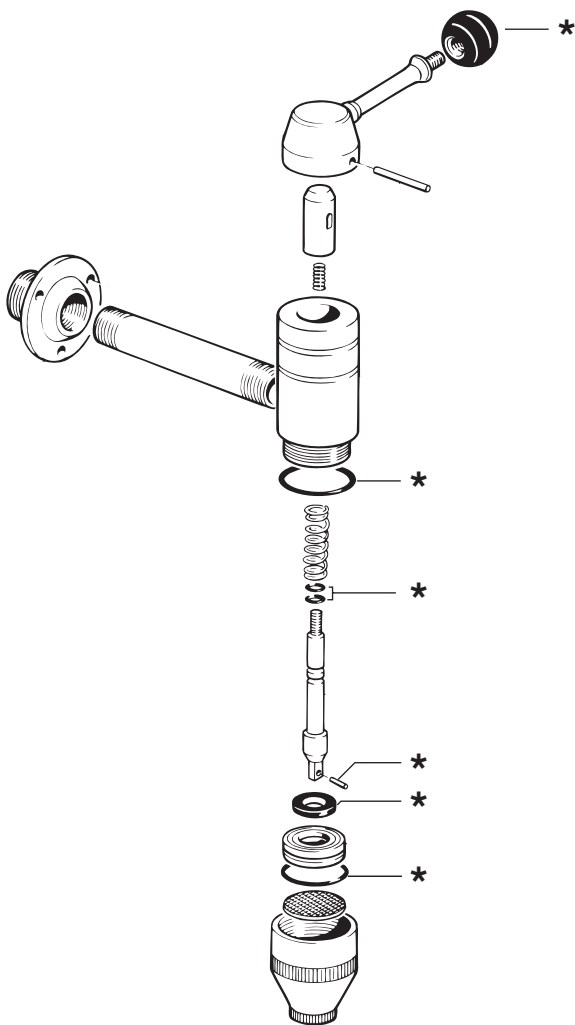

## Steel Auto Shut-off Faucet (with Black Ball Knob)

The Steel Auto Shut-off Faucet can be removed and replaced as needed. There are also spare parts available for the Steel Auto Shut-off Faucet as noted by asterisks in Figure 7 on the left.

### Filters

Remove housing and filter element. Replace with same Part#.

### Suction Hose Assembly - Stainless Steel Tube with Reinforced PVC Hose

The Suction Hose Assembly used to load fluid from 55 gallon drums can be replaced. Contact your supplier for additional information.

**FIGURE 7:**

*Schematic Steel Auto Shut-Off Faucet*

## TANK OR MOTOR REPLACEMENT

For repair or replacement of motor, contact your supplier for ordering information. The motor/pump assembly is secured to the pod using a removable skid which is bolted to the pod. For motor removal and replacement, disconnect all lines from the motor/pump and remove the skid bolts. The motor/pump skid can then be pulled out and the new motor/pump can be set into place and connected.

When servicing, removing, or replacing parts, there may be specific tools required. Table 2 below lists tool specifications for servicing, removing, or replacing equipment.

**TABLE 2: Tools and Wrench List**

<b>Item Description</b>	<b>Fastener</b>	<b>Tool</b>	<b>Size</b>
Dispensing Console - Faucet Mounting Screws	No. 10/24 Cap Screws	Hex Key	1/8"
Dispensing Console - Pressure Gauge Face Mounting Screws	No. 6 Cap Screws	Hex Key	5/64"
Dispensing Console - Stainless Splash Plate - Mounting Screws	5/16" UNC Cap Screws	Hex Key	3/16"
Dispensing Console - Steel Mounting Plate Screws	5/16" UNC Cap Screws	Hex Key	3/16"
Hose Connections - all discharge hydraulic hose connections	3/4" JIC Hose Coupler	Wrench	1-1/4"
Hose Connections - all pump by-pass return hose connections	1/2" JIC Hose Coupler	Wrench	7/8"
Hose Connections - all suction hydraulic hose connections	1" JIC Hose Coupler	Wrench	1-1/2"
Hose Connections - all system pressure gauge hose connections	1/4" JIC Hose Coupler	Wrench	9/16"
Hose Connections - Dixon Cam & Groove Coupling (Male Adaptor)	1" NPT Male Adaptor	Wrench	1-1/2"
Motor - Holding Down Bolts	5/16" UNC Bolt	Wrench	1/2"
Motor/Pump Skid - Holding Down Bolts	3/8" UNC Bolt	Wrench	9/16"

**TABLE 1: Spare and Replacement Parts List**

<b>Item Description</b>	<b>Type</b>	<b>Part #</b>
Colored Ball Knob for Steel Faucet Shut Off Valve - Beige	Ball Knob	921000
Colored Ball Knob for Steel Faucet Shut Off Valve - Black	Ball Knob	921001
Colored Ball Knob for Steel Faucet Shut Off Valve - Blue	Ball Knob	921002
Colored Ball Knob for Steel Faucet Shut Off Valve - Dark Green	Ball Knob	921003
Colored Ball Knob for Steel Faucet Shut Off Valve - Gray	Ball Knob	921004
Colored Ball Knob for Steel Faucet Shut Off Valve - Mid Green	Ball Knob	921005
Colored Ball Knob for Steel Faucet Shut Off Valve - Orange	Ball Knob	921006
Colored Ball Knob for Steel Faucet Shut Off Valve - Purple	Ball Knob	921007
Colored Ball Knob for Steel Faucet Shut Off Valve - Red	Ball Knob	921008
Colored Ball Knob for Steel Faucet Shut Off Valve - Yellow	Ball Knob	921009
Tank Desiccant Air Breather	Breather	46Z134
Suction Hose Assembly - Stainless Steel Tube with Reinforced PVC Hose	Tube	921300

# OilSafe Drum Dispensing System Plumbing Schematic - Rev2

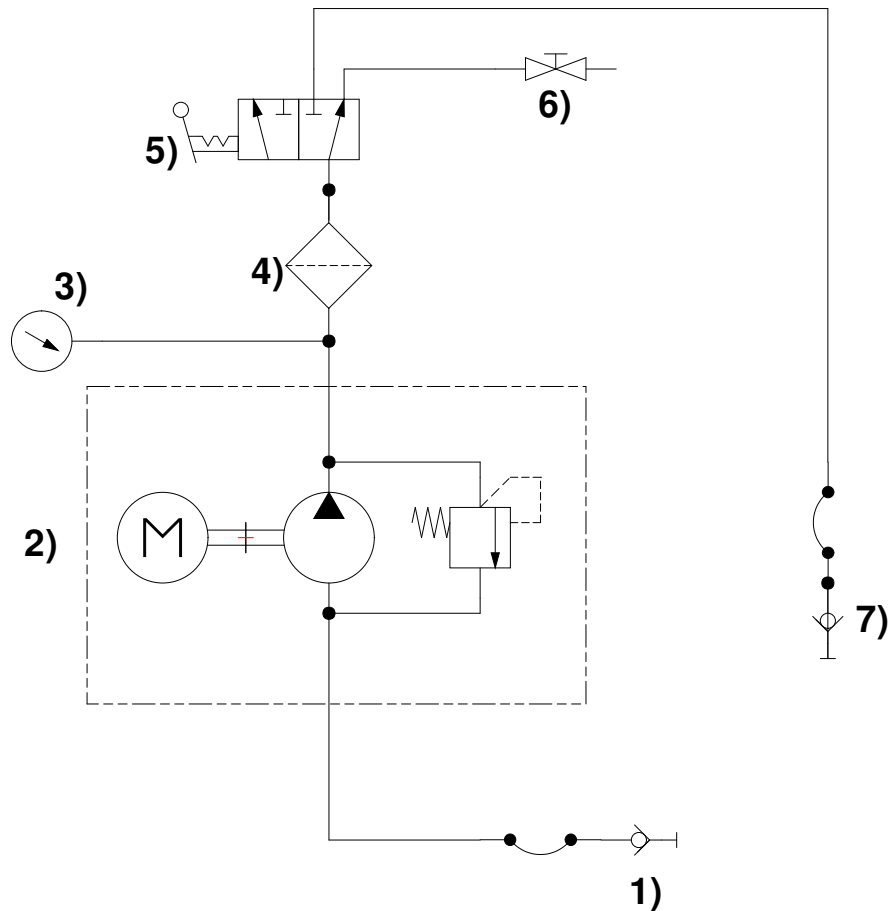

- 1) Suction wand & adapter or optional quick disconnect for suction
- 2) 1HP-1200rpm motor & 3gpm(11.4lpm) 150psi(10.3bar) pump  
or Pneumatic diaphragm pump
- 3) Pressure gauge
- 4) Oil filter with condition indicator
- 5) 3-Way ball valve for dispense or recirculation
- 6) Dispensing tap
- 7) Return connection to drum or optional quick disconnect

## CUSTOMER SERVICE AND WARRANTY ISSUES

For any customer service, ordering requests, or warranty issues, please contact your authorized supplier or OilSafe.

*You may contact OS as follows:*



930 Whitmore Drive  
Rockwall, TX USA

Telephone: (972) 771-1000

Fax: (972) 722-3252

Email: [sales@oilsafe.com](mailto:sales@oilsafe.com)

[www.oilsafe.com](http://www.oilsafe.com)









**930 Whitmore Drive  
Rockwall, TX USA**

**Telephone: (972) 771-1000  
Fax: (972) 722-3252  
Email: sales@oilsafe.com  
www.oilsafe.com**